

marco zagaria

abstract chair, armchairs, containers

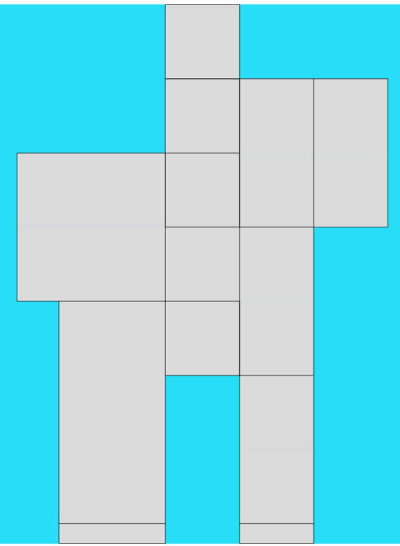

"slash" chair
2017

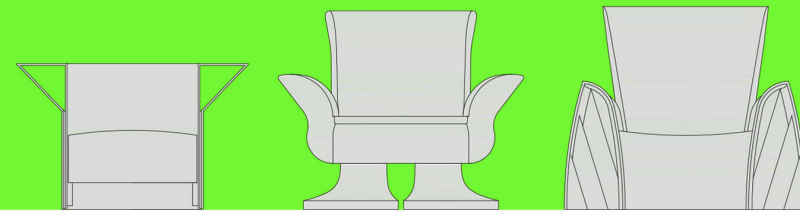
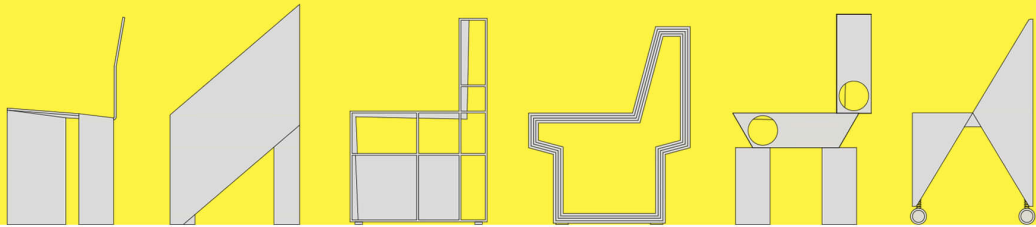
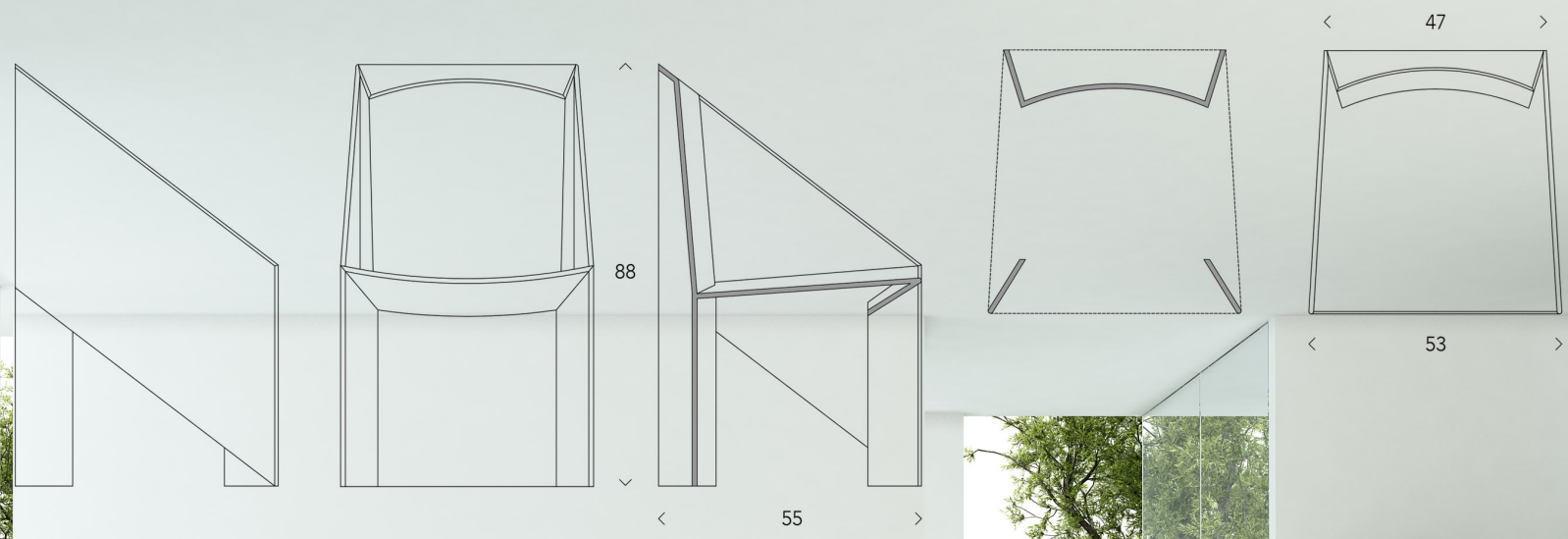

"slash" chair 2017

With an essential but not minimal design, this chair is simple but impressive. Its sharp oblique line softens the distinction between armrest and backrest, giving it the elegance of an armchair even in the small size of a chair; the trapezoidal flare increases this welcoming effect while the concave shape of the backrest and seat makes it comfortable and ergonomic.

Its clean and modern line makes it suitable for contemporary contexts by imposing it in space and at the same time its material neutrality allows it to be combined in an extremely versatile way to the most diverse contexts.

Available in polycarbonate, abs or polyamide, it lends itself well to a chromatic palette, which starting from bright transparencies can reach bright green or bright yellow up to total white.



"slash b" chair 2017

Version with the Slash armrests amplifies the character of an armchair that can also be comfortably used in the living room or in front of a desk. Furthermore, both for the material with which it can be made and for the vivacity of the colors, it is perfectly suitable for both indoor and outdoor use.

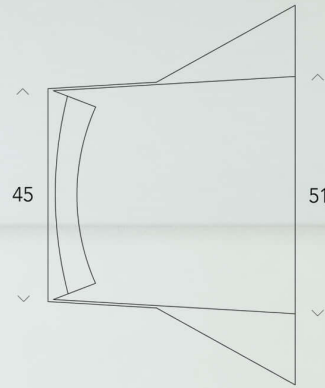

"frame" chair 2016

This chair is a frame that encloses the void but which if necessary can contain something material: books, a bag, a jacket, an imac, a cushion ... with its angular shape and its grooved profile it frames the space as if it were a background and winking at the surrealist works from which it draws inspiration.

The formal choice of revisiting the concept of decoration, typical of the classical tradition, places the Frame chair in the guise of an ambivalent object, making it fit harmoniously, even in classic environments, introducing a touch of novelty without trauma, in fact it also goes well with with the classic wooden and lacquered wood tables giving a result of original but sober contrast. From an ergonomic point of view, despite the angular lines, both the backrest and the seat follow the body line allowing a comfortable posture that make it suitable for relaxing breaks even outside on the terrace or in the garden.

Available in polycarbonate, abs or polyamide, it lends itself well to a chromatic palette, which starting from bright transparencies can reach bright green or bright yellow up to total white.

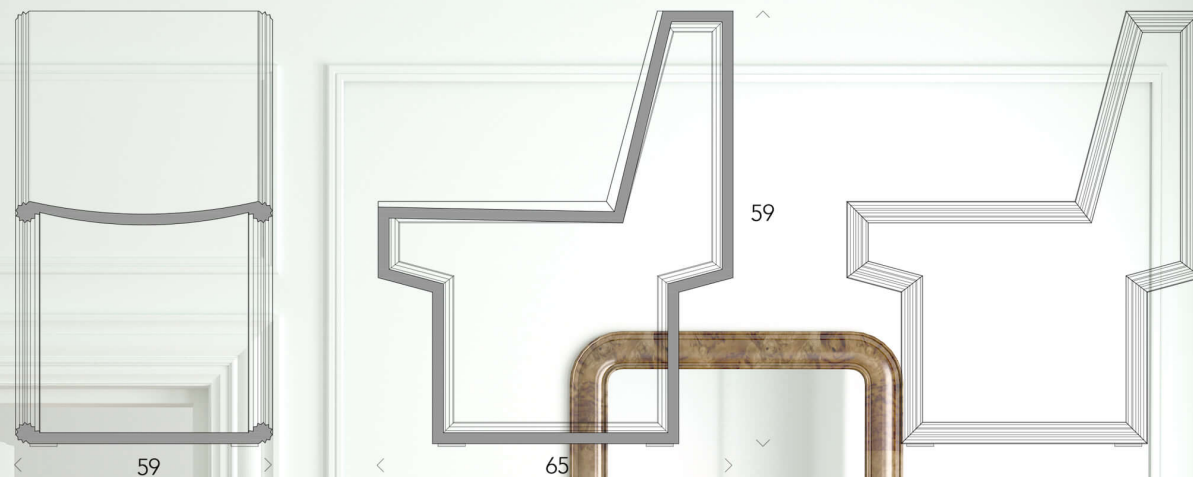

"origami" chair
2017



"origami" chair 2017

As in origami, few types of folds are used to combine an infinite variety of models, this chair also started with the use of primary geometric figures to create a complex shape that revisited the idea of the classic four-footed chair. Origami is thus detached from the ground, a spacecraft that tries to anchor itself to the ground through four thin point objects and a light polycarbonate structure. To increase the sense of lightness and to give it a touch of irony and nonsense, there is the addition, in addition to the steel feet, also of micro spring shock absorbers and swivel wheels, all interchangeable according to the different functional and setting requirements. Its shape, its gadgets and its transparency make the design of this chair incredibly light, impalpable, ironic and comfortable, ideal for completing the minimal interior in a lively way but also suitable for more classic furnishings, breaking the monotony through color and the innovative design.

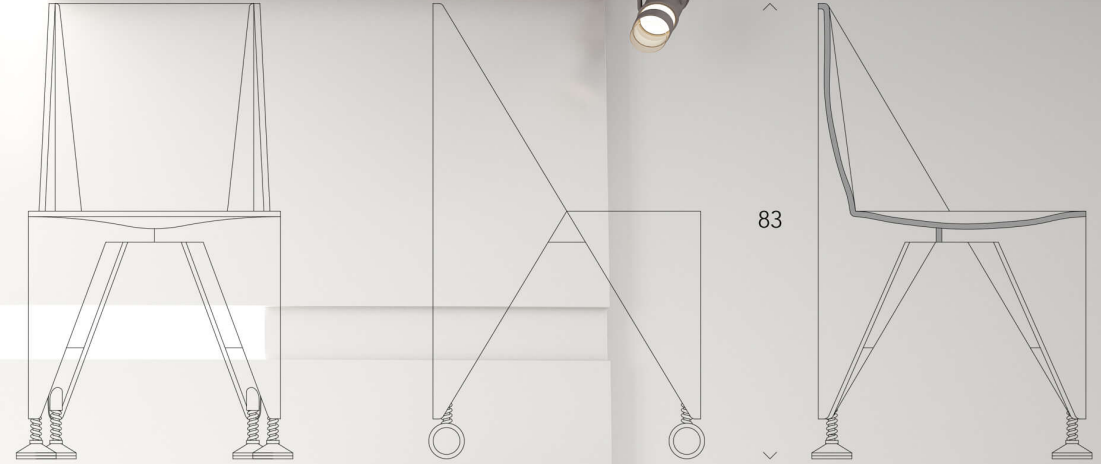

83

49

39

46



"legoluilegolei" container 2017

Inspired by Lego bricks, this container is made up of two connected parts that intersect giving it a vaguely anthropomorphic aspect from which the pun of its name is derived.

Its function is multiple and customizable thanks to the use of various additional modules.

The structure, of important dimensions, is composed of modules connected to each other through steel and rubber joints and rests on two mobile bases.

Its plasticity, the absence of a front and a back, the tilting wheels, allows it to fill the space and move, placing itself at the center of the rooms.

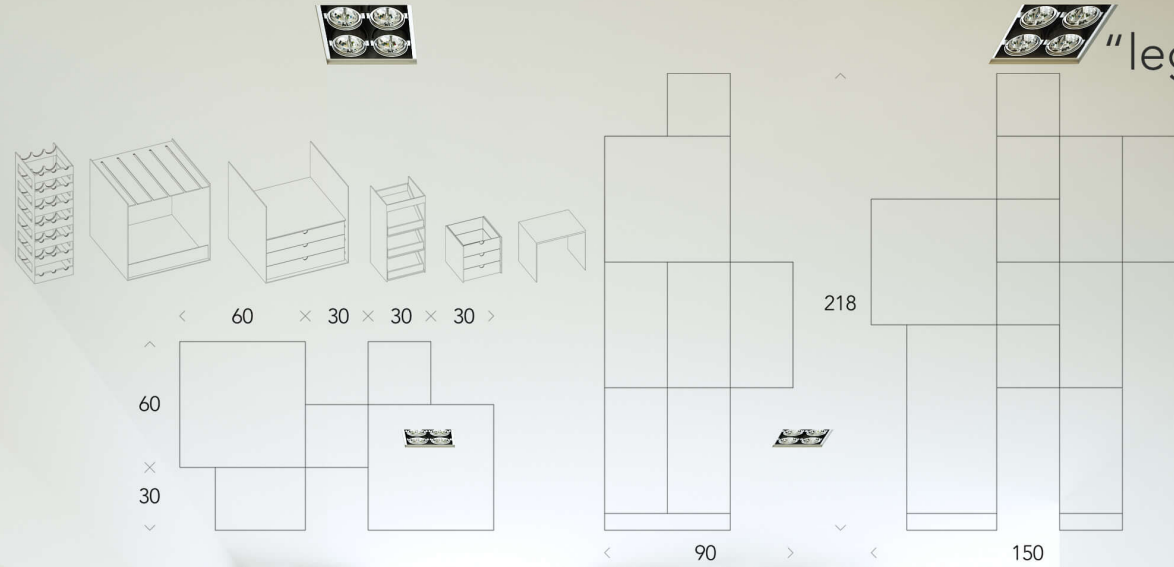

"45" armchair 2018

The leitmotiv of this armchair is to break the prejudice of uncomfortable plastic by introducing the visible surprise of a soft seat and back. Its originality is found not only in the polished steel springs that make it particularly comfortable even in the 45 degree folds of the armrests that lighten the structure by letting air pass and allowing you to house the telephone or remote control. The repetition of the module at 45 degrees also for the backrest increases its elegance as well as having an extra shelf to place a glass, store a book or other object, useful for an informal and colorful aperitif both at home than in the garden.

Also available in the two-seater version, the 45 armchair can be made either in polycarbonate which enhances its transparency characteristics or in polyethylene which gives it further plasticity.

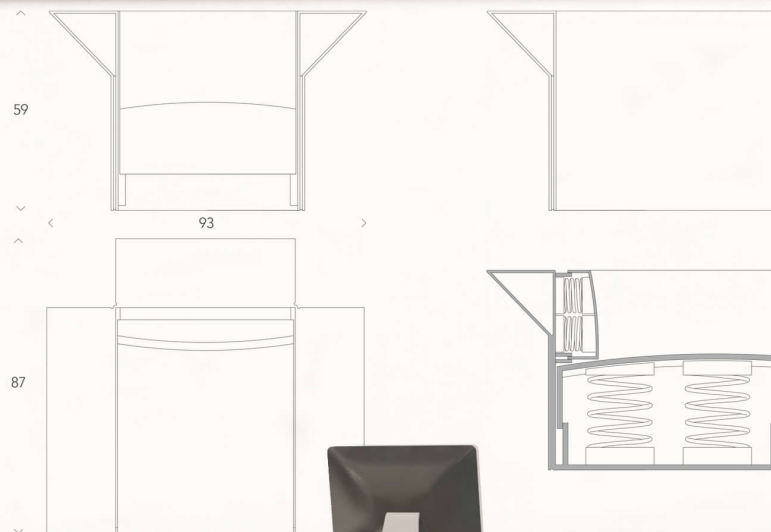

"chunks"
2020

This dis/mountable chair is contained in a box of only 50 cm side and 16 cm height. It is composed of a seat and eight identical pieces that serve as feet, uprights and backrests that can be easily attached to each other. This simplicity of the module allows the pieces to be assembled into an infinite number of compositions that make it aesthetically versatile and different. It can be made of polycarbonate, ABS or polyamide and lends itself well to a chromatic palette that starts with lively transparencies and goes from dull green or straw yellow to total transparency.

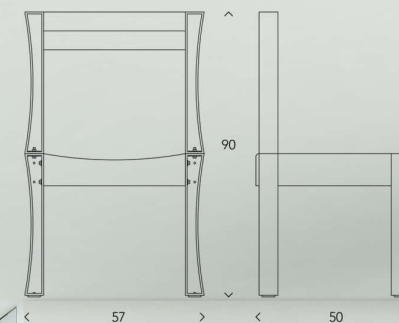
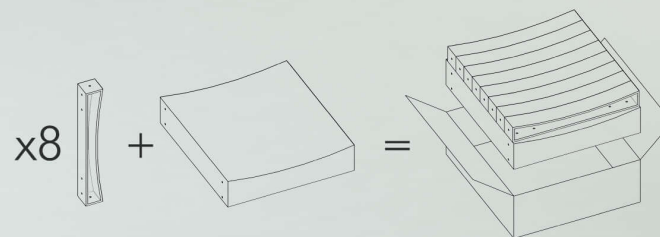

"fibo" chair
2018



Seemingly minimalist, this chair stands as a real architecture made up of interiors and exteriors regulated by the golden Fibonacci numerical series. In spite of the rigid and squared ensemble, the seat and back are concave, slightly inclined and welcoming. The structure alternates full and empty spaces designed precisely to store personal items of current use such as the telephone or glasses instead of leaving them on the table but also to accommodate more bulky objects such as a bag. Available in transparent polycarbonate, it can also be more three-dimensional through the use of polyamide or polyethylene.

"fibo" chair
2018



"montblanc" armchair 2019

Montblanc is inspired by the peaks by solving in an original way the idea of armrest and backrest that become peaks and caves crossed by deep rocky diagonals. It is a stately and eclectic armchair at the same time that synthesizes an impression through complex but welcoming shapes. Available in polycarbonate or rotational-molded tecnoprene, it can have a leather seat and glossy or faux metal finishes.

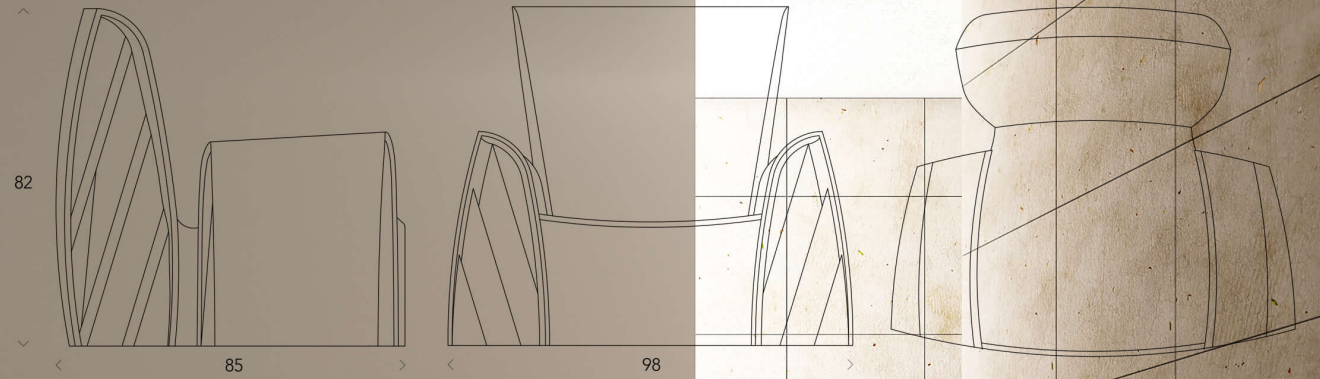

"folding" chair 2017

Also for this project, the goal was to reconsider the idea of a chair - this time folding - by designing one that stands out from the others both in shape and fold. In fact, Folding does not have the appearance of a folding chair but rather looks like a small throne firmly planted on the floor. It also differs in the folding that occurs along the longitudinal axis rather than the transverse one through simple hinged joints between the panels. Thanks to this design and the minimum thicknesses due to the use of plastic, its footprint is only 5 cm; it can be stacked in a container trolley or hung on the special hook which makes it the perfect decorative element with which to customize and color the walls of the rooms. Available, depending on the desired finish, in polycarbonate, abs or polypropylene plastic reinforced with glass fiber.

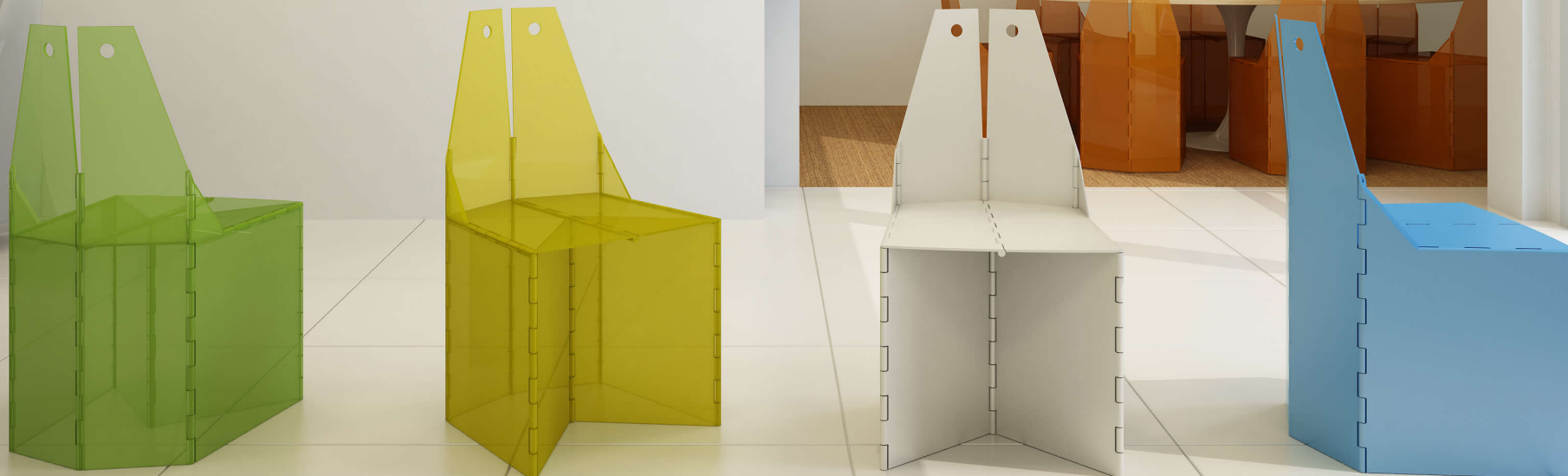
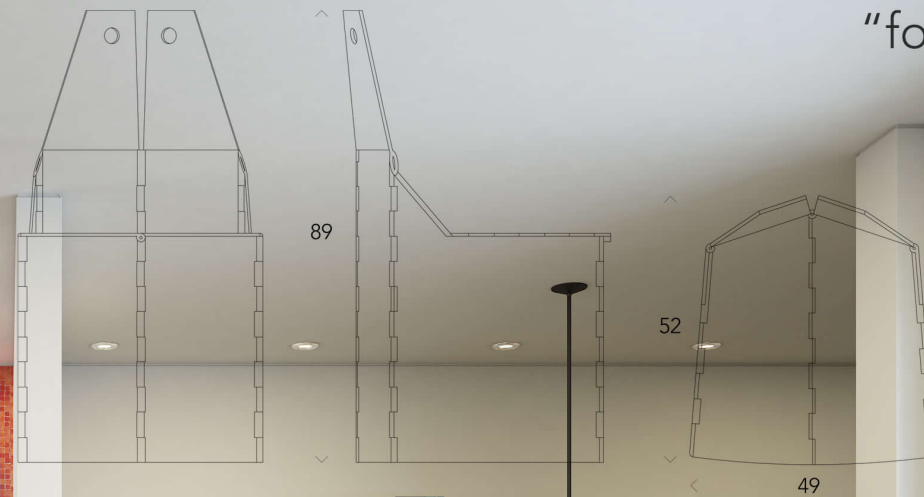

"shunt" chair
2017

Shunt continues the research started with the Origami and Slash chairs on the use of thin folded and shaped tops to create essential plastic shapes. Here, however, the structure is more solid and complex, a real light and heavy micro-architecture depending on the point from which it is observed. The use of blades of varying sizes for the feet gives it an original and eccentric dynamism that is also transmitted to the backrest and seat, whose design accentuates their comfort.

A dynamic style that brings a touch of novelty and youth to what is the reinterpretation of the classic living room chair. Finally, versatility, given by its informality and the way in which it manages to integrate into the environment, without sacrificing its dose of elegance and refinement. Shunt has the characteristic of combining an attractive design with a comfortable, solid and stable composition that does not sacrifice the comfort of the seat.

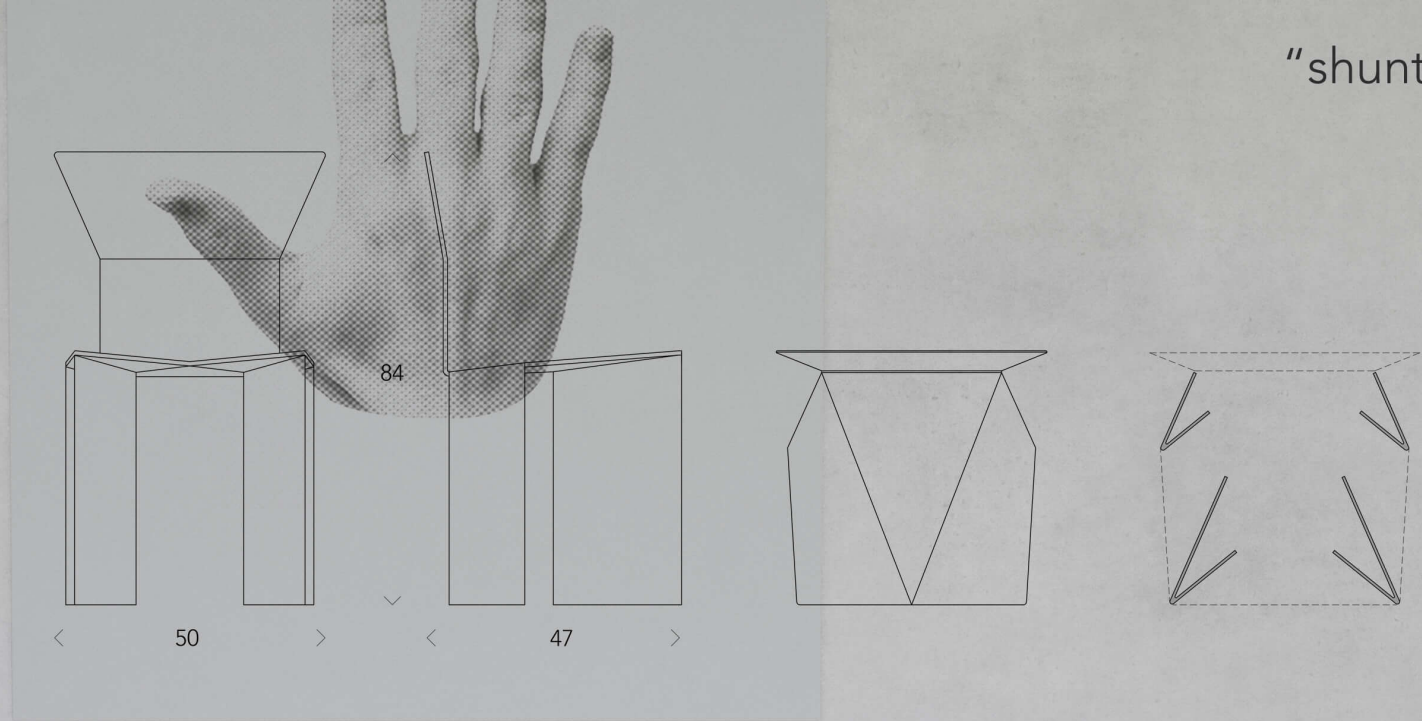

With its eccentric and duckling shape, this armchair can literally try to fly. In spite of the rigid material, in fact, the whole seat rests on four generous and sprung feet that make it comfortable, welcoming and awkwardly tilting. Available in metallized polycarbonate or in opaque rotationally molded tecnoprene, it is also suitable for outdoor use.

"try to flyng" armchair 2019

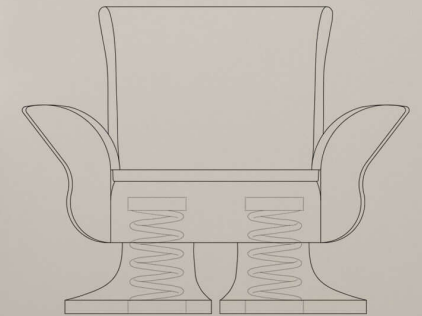
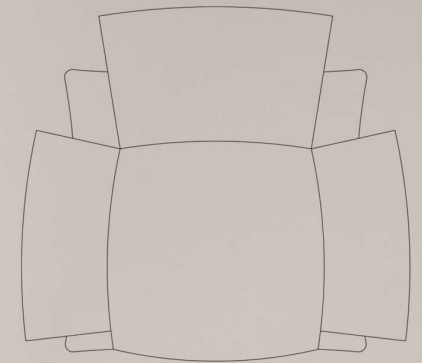

100



The idea of a chair is usually well defined within us as an object with which we come into contact every day and towards which we have a well-defined mental model both on its shape and on its use. Our imagination remains essentially trapped within stereotyped patterns and for this reason the idea of the Glovebox chair is an exhortation to go beyond the traditional models with which we live. Therefore, it presents itself as a chair-container with a pop-robotic taste that, taking its cue from the glove boxes of the laboratories, mixes everything up following the principle that hybridization creates new energy and forms.

From a functional point of view Glovebox expands the concept of seating allowing the user to complementary actions such as putting away a book, a telephone, keys, cigarettes, but also placing a cup, a can or placing a pail, a scarf, a soft pillow.

With important lines, it can be made in polycarbonate but also in rotational molded polyethylene and is ideal for both outdoor and indoor. The use of bright colors makes it particularly useful for reviving and breaking the monotony of "minimal" monochromatic interiors.

